

## Solid State Relay Input

One of the main components of a solid-state relay (SSR) is an opto-isolator (also called an optocoupler) which contains one (or more) infra-red light-emitting diode, or LED light source, and a photo sensitive device within a single case. The opto-isolator isolates the input from the output.

The LED light source is connected to the SSR's input drive section and provides optical coupling through a gap to an adjacent photo sensitive transistor, Darlington pair or triac. When a current passes through the LED, it illuminates and its light is focused across the gap to a photo-transistor/photo-triac.

Thus, the output of an opto-coupled SSR is turned "ON" by energizing this LED, usually with low-voltage signal. As the only connection between the input and output is a beam of light, high voltage isolation (usually several thousand volts) is achieved by means of this internal opto-isolation.

Not only does the opto-isolator provide a higher degree of input/output isolation, it can also transmit dc and low-frequency signals. Also, the LED and photo-sensitive device could be totally separate from each other and optically coupled by means of an optical fibre.

The input circuitry of an SSR may consist of just a single current limiting resistor in series with the LED of the opto-isolator, or of a more complex circuit with rectification, current regulation, reverse polarity protection, filtering, etc.

To activate or turn "ON" a solid-state relay into conduction, a voltage greater than its minimum value (usually 3 volts DC) must be applied to its input terminals (equivalent to the electro-mechanical relay coil). This DC signal may be derived from a mechanical switch, a logic gate or micro-controller, as shown.

## Solid State Relay DC Input Circuit

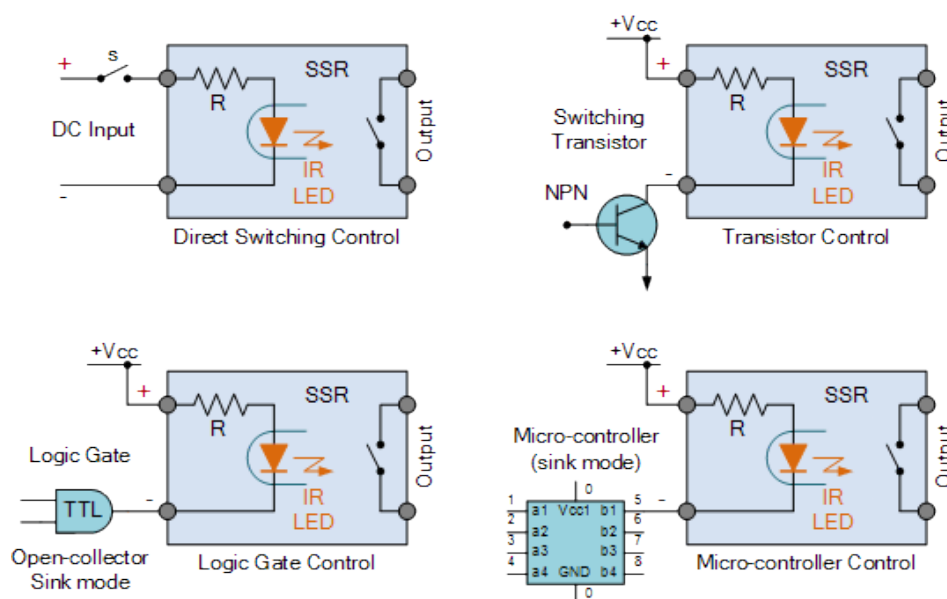

When using mechanical contacts, switches, push-buttons, other relay contacts, etc., as the activating signal, the supply voltage used can be equal to the SSR's minimum input voltage value, whereas when using solid state devices such as transistors, gates and micro-controllers, the minimum supply voltage needs to be one or two volts above the SSR's turn-on voltage to account for the switching devices internal voltage drop.

But as well as using a DC voltage, either sinking or sourcing, to switch the solid-state relay into conduction, we can also use a sinusoidal waveform as well by adding a bridge rectifier for full-wave rectification and a filter circuit to the DC input as shown.

### Solid State Relay AC Input Circuit

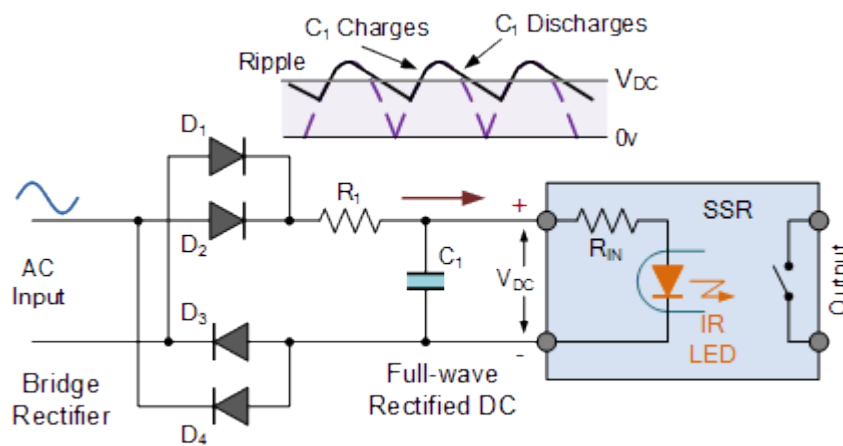

Bridge rectifiers convert a sinusoidal voltage into full-wave rectified pulses at twice the input frequency. The problem here is that these voltage pulses start and end from zero volts which means that they will fall below the minimum turn-on voltage requirements of the SSR's input threshold causing the output to turn "on" and "off" every half cycle.

To overcome this erratic firing of the output, we can smooth out the rectified ripples by using a smoothing capacitor, (C1) on the output of the bridge rectifier. The charging and discharging effect of the capacitor will raise the DC component of the rectified signal above the maximum turn-on voltage value of the solid-state relays input. Then even though a constantly changing sinusoidal voltage waveform is used, the input of the SSR sees a constant DC voltage.

The values of the voltage dropping resistor, R1 and the smoothing capacitor, C1 are chosen to suit the supply voltage, 120 volts AC or 240 volts AC as well as the input impedance of the solid-state relay. But something around 40k $\Omega$  and 10uF would do.

Then with this bridge rectifier and smoothing capacitor circuit added, a standard DC solid state relay can be controlled using either an AC or non-polarized DC supply. Of course, manufacturers produce and sell AC input solid state relays (usually 90 to 280 volts AC) already.

## Solid State Relay Output

As with the input, the output switching capabilities of a solid-state relay can be either an AC or DC voltage. The output circuit of most standard solid-state relays are configured to perform only one type of switching action giving the equivalent of a normally-open, single-pole, single-throw (SPST-NO) operation of an electro-mechanical relay.

For most DC SSR's the solid-state switching device commonly used are power transistors, Darlington's and MOSFETs. For an AC SSR, the switching device is either a Triac or two inverse-parallel connected silicon-controlled rectifiers (SCR's) to allow for bidirectional switching. Note that a Triac is nothing more than two SCRs connected in inverse-parallel, with their gates connected together.

Silicon controlled rectifiers (thyristors) are generally preferred due to their high voltage and current capabilities. A single SCR can also be used within a bridge rectifier circuit as shown to short out the bridge at the required firing angle.

## Solid State Relay Output Circuit

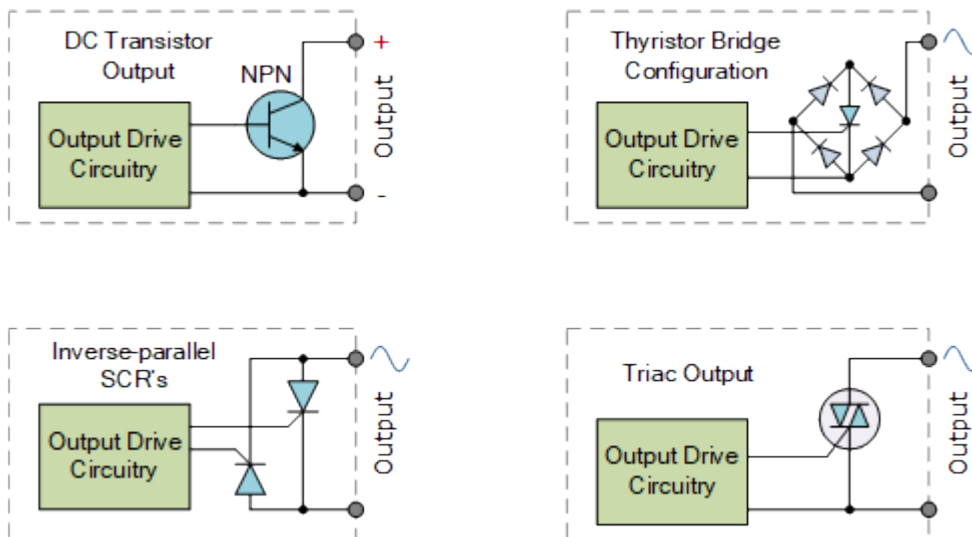

The most common application of solid-state relays is in the switching of an AC load, whether that is to control the AC power for ON/OFF switching, light dimming, motor speed control or other such applications where power control is needed, these AC loads can be easily controlled with a low current DC voltage using a solid-state relay providing long life and high switching speeds.

One of the biggest advantages of solid-state relays over an electromechanical relay is its ability to switch “OFF” AC loads at the point of zero load current, thereby completely eliminating the arcing, electrical noise and contact bounce associated with conventional mechanical relays and inductive loads.

This is because AC switching solid state relays use SCR's and TRIACs as their output switching device which continues conducting, once the input signal is removed, until the AC current flowing through the device falls below its threshold or holding current value. Then the output of an SSR can never switch OFF in the middle of a sine wave peak.

Zero current turn-off is a major advantage for using a solid-state relay as it reduces electrical noise and the back-emf associated with the switching of inductive loads as seen as arcing by the contacts of an electro-mechanical relay. Consider the output waveform diagram below of a typical AC solid state relay.

### Solid State Relay Output Waveform

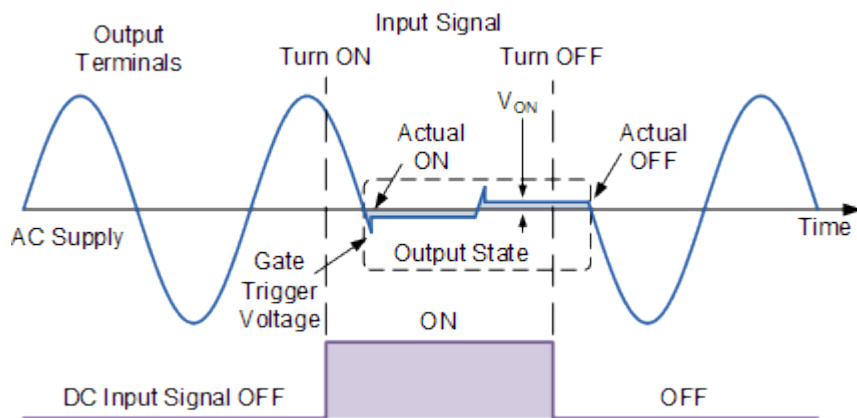

With no input signal applied, no load current flows through the SSR as it is effectively OFF (open-circuited) and the output terminals see the full AC supply voltage. With the application of a DC input signal, no matter which part of the sinusoidal waveform, either positive or negative the cycle is going through, due to zero-voltage switching characteristics of the SSR, the output only turns-on when the waveform crosses over the zero point.

As the supply voltage increases in either a positive or negative direction, it reaches the minimum value required to turn the output thyristors or Triac fully ON (usually less than about 15 volts). The voltage drop across the SSR's output terminals is that of the switching devices on-state voltage drop,  $V_T$  (usually less than 2 volts). Thus, any high inrush currents associated with reactive or lamp loads are greatly reduced.

When the DC input voltage signal is removed, the output does not suddenly turn-off as once triggered into conduction, the thyristor or Triac used as the switching device stays ON for the remainder of the half cycle until

the load currents drops below the devices holding current, at which point it switches OFF. Thus, the high dv/dt back emf's associated with switching inductive loads in the middle of a sine wave is greatly reduced.

Then the main advantages of the AC solid state relay over the electro-mechanical relay are its zero-crossing function which turns ON the SSR when the AC load voltage is close to zero volts, thus suppressing any high inrush currents as the load current will always start from a point close to 0V, and the inherent zero current turn-off characteristic of the thyristor or triac. Therefore, there is a maximum possible turn-off delay (between the removal of the input signal and the removal of load current) of one-half cycle.

## Analog Switching

Since the 4-20mA or 0-10VDC control input of the analog relay can be varied, the output operates in accordance with the phase control principle. The relay is equipped with a built-in synchronization circuit in order to achieve phase angle control. The output is proportional to the input signal. The transfer function is linearized and reproducible.

These SSRs are highly advantageous in closed loop applications or where soft starting can limit high inrush currents. Ideal for use in switching quartz heaters or in applications which demand precise temperature control.

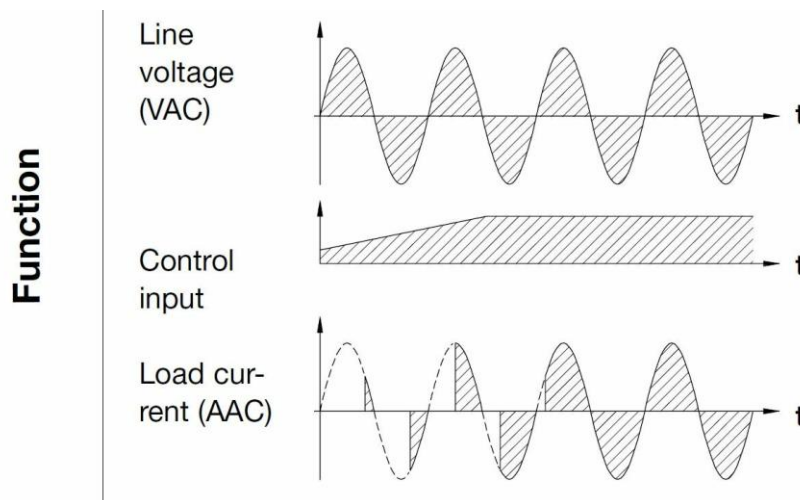

## Analog Full Cycle Switching:

For resistive loads.

With this particular switching principle, the SSR provides a number of full cycles, evenly distributed over a fixed time period, depending on the control input (either 4-20mA or 0-10VDC) – with the low value of the input corresponding to zero and the high value of the input to a full output with a period of 1.28 seconds.

Typical applications include: analog control of heating elements with mount or automatic controllers with 4-20mA or 0-10VDC control signal. Control of heating zones, analog control of fragile heating elements which are used for cutting, welding, etc. which can have their lifetime extended due to the reduced thermal load stress.

## Phase Dimming Solid State Relay

While solid state relays can perform straight forward zero-crossing switching of a load, they can also perform much more complicated functions by means of digital logic circuits, microprocessors and memories. Another excellent application of a solid-state relay is in lamp dimming applications, whether in the home or for a show or concert.

Non-zero (instant-on) switching solid state relays turn-on immediately after the application of the input control signal as opposed to the zero crossing SSR above which waits until the next zero-crossing point of the AC sine-wave. This random-fire switching is used in resistive applications such as lamp dimming and applications that require the load only to be energized for a small portion of the AC cycle.

## Random Switching Output Waveform

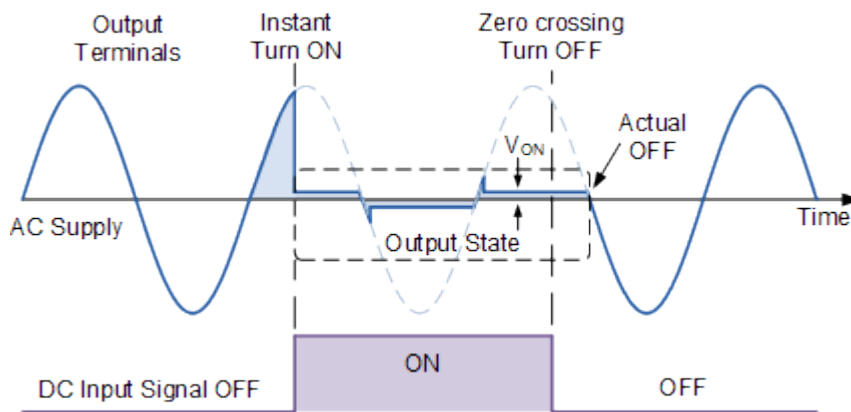

While this allows for the phase control of the load waveform, the main problem random turn-on SSR's is that the initial load surge current at the instant the relay turns-on, may be high due to the SSR switching power when the supply voltage is close to its peak value (90°). When the input signal is removed, it stops conducting when the load current falls below the thyristors or triacs holding current as shown. Obviously for a DC SSR, the ON-OFF switching action is instant.

The solid-state relay is ideal for a wide range of ON/OFF switching applications as they have no moving parts or contacts unlike an electro-mechanical relay (EMR). There are many different commercial types to choose from for both AC and DC input control signals as well as AC and DC output switching as they employ semiconductor switching elements, such as thyristors, triacs and transistors.

But by using a combination of a good opto-isolator and a triac, we can make our own inexpensive and simple solid-state relay to control an AC load such as a heater, lamp or solenoid. As an opto-isolator only needs a small

amount of input/control power to operate, the control signal could be from a PIC, Arduino, Raspberry PI, or any other such micro-controller.

### Example No1

Let's assume we want a micro-controller with a digital output port signal of only +5 volts to control a 120V AC, 600-watt heating element. For this we could use the MOC 3020 opto-triac isolator, but the internal triac can only pass a maximum current (ITSM) of 1 Amps peak at the peak of a 120V AC supply so an additional switching triac must also be used.

First let's consider the input characteristics of the MOC 3020 opto-isolator (other opto-triacs are available). The opto-isolator's datasheet tells us that the forward voltage, (VF) drop of the input light emitting diode is 1.2 volts and the maximum forward current, (IF) is 50mA.

The LED needs about 10mA to shine reasonably brightly up to its maximum value of 50mA. However, the digital output port of the micro-controller can only supply a maximum of 30mA. Then the value of current required lies somewhere between 10 and 30 milli-amperes. Therefore:

$$R_{MAX} = \frac{V_S - V_F}{10mA} = \frac{5 - 1.2}{0.01} = 380\Omega$$

$$R_{MIN} = \frac{V_S - V_F}{30mA} = \frac{5 - 1.2}{0.03} = 126\Omega$$

Thus, a series current limiting resistor with a value between 126 and 380Ω's can be used. As the digital output port always switches +5 volts and to reduce the power dissipation through the opto-coupler's LED, we will choose a preferred resistive value of 240Ω's. This gives an LED forward current of less than 16mA. In this example, any preferred resistor value between 150Ω and 330Ω's would do.

The heating element load is 600 watts resistive. Using a 120V AC supply would give us a load current of 5 amperes ( $I = P/V$ ). As we want to control this load current in both half cycles (all 4 quadrants) of the AC waveform, we would require a mains switching triac.

The BTA06 is a 6 amps (IT(RMS)) 600-volt triac suitable for general purpose ON/OFF switching of AC loads, but any similar 6 to 8 amp rated triac would do. Also, this switching triac requires only 50mA of gate drive to start conduction which is far less than the 1-amp maximum rating of the MOC 3020 opto-isolator.

Consider that the output triac of the opto-isolator has switched ON at the peak value (90°) of the 120VRMS AC supply voltage. This peak voltage has a value of:  $120 \times 1.414 = 170V_{pk}$ . If the opto-triac's maximum current

(ITSM) is 1 ampere peak, then the minimum value of series resistance require is  $170/1 = 170\Omega$ 's, or  $180\Omega$ 's to the nearest preferred value. This value of  $180\Omega$ 's will protect the opto-coupler output triac, as well as the gate of the BTA06 triac on a 120VAC supply.

If the triac of the opto-isolator switches ON at the zero-crossover value (0o) of the 120VRMS AC supply voltage, then the minimum voltage required to supply the required 50mA gate drive current forcing the switching triac into conduction will be:  $180\Omega \times 50\text{mA} = 9.0$  volts. Then the triac fires into conduction when the sinusoidal Gate-to-MT1 voltage is greater than 9 volts.

Thus, the minimum voltage required after the zero crossover point of the AC waveform would be 9 volts peak with the power dissipation in this series gate resistor being very small so a  $180\Omega$ , 0.5 watt rated resistor could safely be used. Consider the circuit below.

## An AC SSR Circuit

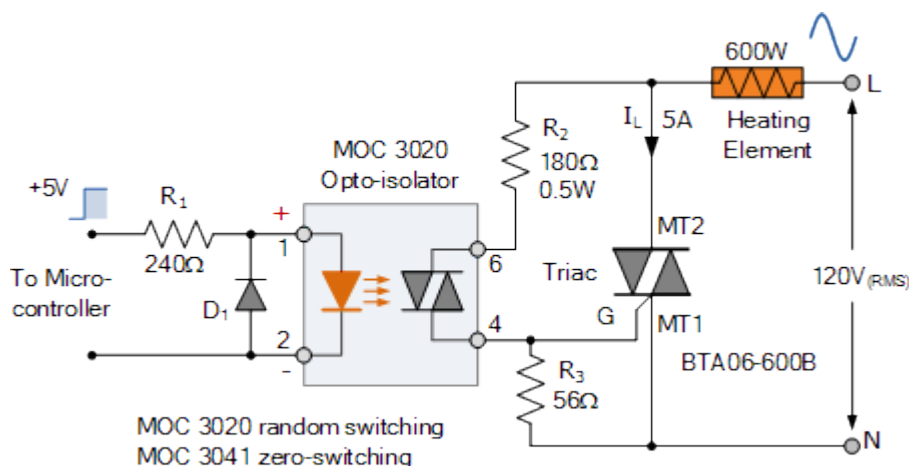

This type of optocoupler configuration forms the basis of a very simple solid state relay application which can be used to control any AC mains powered load such as lamps and motors. Here we have used the MOC 3020 which is a random switching isolator.

The MOC 3041 opto-triac isolator has the same characteristics but with built-in zero-crossing detection allowing the load to receive full power without the heavy inrush currents when switching inductive loads.

Diode D1 prevents damage due to reverse connection of the input voltage, while the 56-ohm resistor (R3) shunts any di/dt currents when the triac is OFF eliminating false triggering. It also ties the gate terminal to MT1 ensuring the triac turns-off fully.





# SENSEMASTER LTD

Sensing, Heating & Anti-static Solutions

Sensemaster Ltd.  
Unit 1 Severn Bridge Ind Est.  
Caldicot, Monmouthshire. NP26 5PW

If used with a pulse width modulated, PWM input signal, the ON/OFF switching frequency should be set to less than 10Hz maximum for an AC load otherwise the output switching of this solid-state relay circuit may not be able to keep up.

Tel 01291 422022

Email: [mail@sensemaster.co.uk](mailto:mail@sensemaster.co.uk)

Web: [www.sensemaster.co.uk](http://www.sensemaster.co.uk)

Director: Stephen Davies

VAT Reg No 412781955

Registered in Wales 1852673