



Customer Service and Product
Quality Are Our No.1 Priority

Terwin μ 600P Multi-function process indicator / alarm controller for use with extrusion pressure transducers, hydraulic pressure sensors, load cells, T/C's, RTD's, voltage & current loop inputs.



Description:

The Terwin μ 600P is a high performance process indicator / alarm controller. User configurable input and output options allow this instrument to be used in a wide range of industrial and research applications, including the measurement of pressure, weight, temperature from T/C's, RTD's, DC voltage and current loop inputs.

When used with extrusion melt pressure sensors that employ 6 wire 80% negative shunt calibration such as the Terwin 2000 series transducers, the μ 600P provides a simple automatic self-calibration feature for both zero and 80% of the applicable pressure range.

The μ 600P is provided with two alarm relays as standard and these may be configured as 'low' or 'high' with direct or inverse action. Additionally, delays in the relays action may be introduced (up to 20 seconds) and the relays may be latched with manual reset through the front keypads.

Optional outputs include Modbus / RTU RS-485 serial communications and analogue user configurable outputs of 0 - 5V, 0 -10V, 0 - 20mA or 4 - 20mADC. Also, an optional 24VDC output is available for use with transmitters.

This instrument has CE Certification for Safety, EMI Susceptibility, EMI Emission, Harmonics and Voltage Fluctuations.

Advantages:

- ✓ **EASY SMART MENU:**

Once you have set the type of input, you only see items on the menu that are applicable to that setting. Saves time and avoids confusion.
- ✓ Programmable range and setpoint alarm functions.
- ✓ **Melt Pressure one button Auto Zero & 80% Calibration function.**
- ✓ Dual setpoints with relay output on each.
- ✓ **Optional analogue and ModBus / RTU RS-485 outputs (isolated).**
- ✓ 5 digit security password protection.
- ✓ **Switch mode power supply for use on 85-265V 50/60Hz.**
- ✓ **Optional 21 – 53V AC/DC power supply.**
- ✓ **1/4 DIN case (96mm x 96mm) with plug-in electronics for ease of service.**
- ✓ CE approved.



Customer Service and Product
Quality Are Our No.1 Priority

Terwin μ 600P Multi-function process indicator / alarm controller for use with extrusion pressure transducers, hydraulic pressure sensors, load cells, T/C's, RTD's, voltage & current loop inputs.

μ 600P Part Numbers:

μ 600P	1	1	blank
------------	---	---	-------

Example:

Terwin model μ 600P-11 universal programmable process indicator / alarm controller. Fitted with dual alarm relays (programmable), isolated analogue output (programmable) and 85-265V 50/60Hz supply. Case Size: 1/4 DIN.

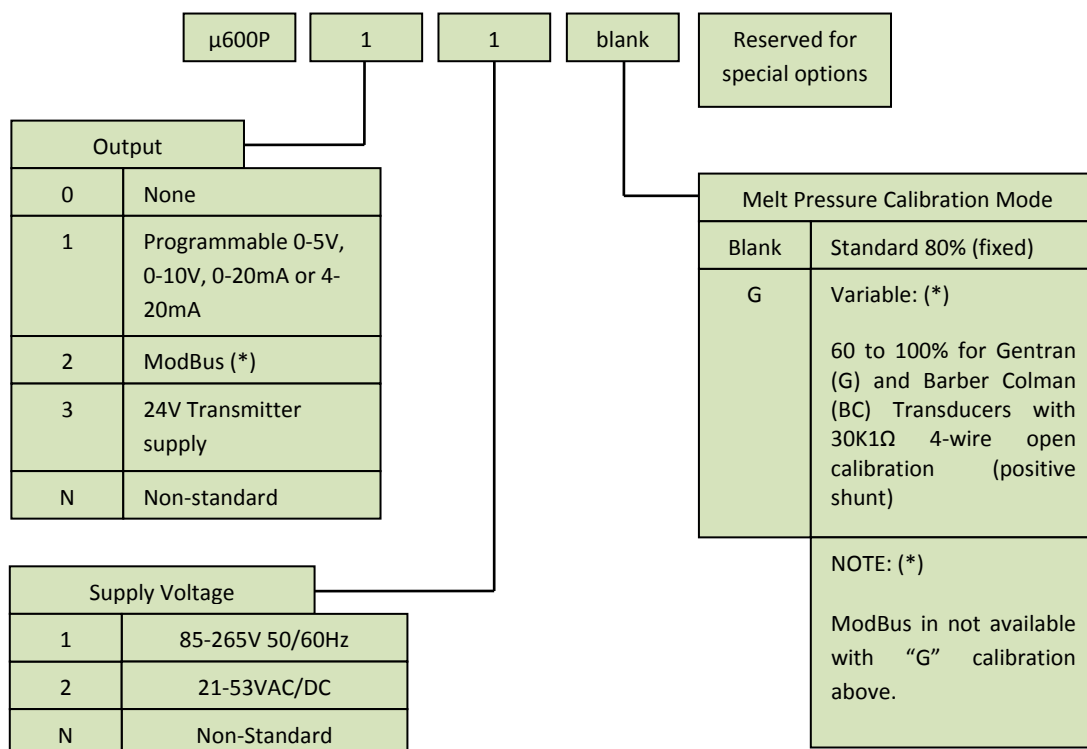



Customer Service and Product
Quality Are Our No.1 Priority

Terwin μ 600P Multi-function process indicator / alarm controller for use with extrusion pressure transducers, hydraulic pressure sensors, load cells, T/C's, RTD's, voltage & current loop inputs.

Specifications

Display:	5 digit red LED 13mm (0.5") high, plus 2 alarm indicators.			
Accuracy:	Better than $\pm 0.25\%$ of full scale value (FSV).			
Inputs:	Strain gauge	Melt Pressure 350 Ω – gauge excitation 10VDC @ 100mA		
		Hydraulic pressure transducers	Load cells	
	Voltage	0-5V DC	0-10V DC	
		Input impedance >1M Ω		
	Current	0-20mA	4-20mA	
		150 Ω load		
Thermocouples	J: 0-600°C or 1,112°F	K: 0-1,200°C or 2,192°F	L: 0-600°C or 1,112°F	N: 0-1,200°C or 2,192°F
	R: 0-1,600°C or 2,912°F	S: 0-1,600°C or 2,912°F	T: 0-400°C or 752°F	
PT100 3-wire	-99.9°C to +200°C or 0150°F to 392°F		-200°C to 600°C or -328°F to 1,112°F.	
Decimal Point:	Programmable through front panel membrane keypad.			
Input Sensitivity:	Applicable to melt pressure transducers only: 1 to 3.7mV/V DC.			
Calibration:	Melt pressure transducers:	Automatic zero and span calibration for melt pressure transducers is provided through the front keypads. For other sensors, please consult the instruction manual.		
Excitation Voltage:	10VDC			
Setpoint Relays – Alarms:	2 SPST relays rated at 1A @250VAC (resistive load). Configurable through front keypads.			
Analogue Outputs:	Optional 0 – 5V, 0 – 10V, 0 – 20mA and 4 – 20mA. User selectable through front keypads and internal DIP switches.			
Serial Communications:	Optional MODBUS / RTU™ protocol.			
Transmitter Supply:	Optional 24VDC @ 40mA.			
Power Supply:	85 – 265V 50/60Hz	Optional 21 to 53VAC/VDC		
Operating Temperature:	0 to 50°C or 122°F			
Storage Temperature:	-10 to 60°C or 140°F			
Relative Humidity:	0 to 95% non-condensing.			
Case:	ABS self extinguishing.			
Dimensions:	96mm wide x 96mm high x 98mm deep (3.78" x 3.78" x 3.86")			
Protection:	IP50			
CE Certification:	Safety, EMI Susceptibility, EMI Emission, Harmonics and Voltage Fluctuations.			

