

Heaters Designed to Heat Forced-Circulation Air, Gases or Liquids

Circulation heaters provide a ready-made means to install electric heating with a minimal amount of time and labor. This is accomplished by combining heating elements, vessel, insulation, terminal enclosure, mounting brackets and inlet and outlet connections into a complete assembly.

Made from National Pipe Thread (NPT) screw plug or ANSI flange heater assemblies mated with a pressure vessel (tank), circulation heaters are designed to heat forced-circulation air, gases or liquids. Ideal for either in-line or side-arm operations, these assemblies direct fluids past WATROD™ heating elements, to deliver fast response and even heat distribution.

Watlow® meets virtually all circulation heater assembly needs with made-to-order units. Watlow circulation heaters can be made from a wide range of heating element sheath materials, wattages, vessel sizes and materials, pressure ratings, terminal enclosures and controls.

Performance Capabilities

- Watt densities up to 120W/in² (18.6 W/cm²)
- Wattages up to three megawatts
- UL® and CSA component recognition up to 690VAC
- Ratings up to ANSI Class 600 pressure class
- Alloy 800/840 sheath temperatures up to 1600°F (870°C)
- Passivated 316 stainless steel sheath temperatures up to 1200°F (650°C)
- Steel sheath temperatures up to 750°F (400°C)

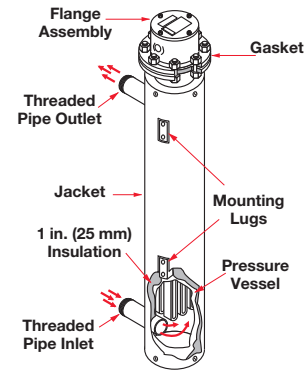
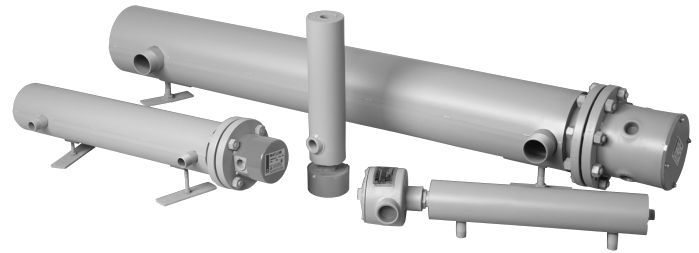

Features and Benefits

Catalog screw plug and flange part numbers

- Provides a wide selection of WATROD elements to meet specific application requirements

Type	Sizes (in.)
NPT screw plugs	1 1/4, 2 1/2
ANSI flanges	3, 4, 5, 6, 8, 10, 12, 14

ANSI B16.5 Class 150 on 4 or 6 inch FIREBAR element flanges and 3 to 14 inch WATROD element flanges

- Meets recognized agency standards

FIREBAR assemblies pack more wattage in a smaller heater bundle

- Replaces larger flanges with round tubular elements, with a smaller package

Compacted mgO insulation filled elements

- Maximizes dielectric strength, heat transfer and life

1 inch (25 mm) thermal insulation rated to 750°F (400°C)

- Reduces heat loss from the vessel

Heavy-gauge steel jacket (shroud)

- Protects thermal insulation and heating vessel and comes with protective primer coating

Features and Benefits *(Continued)*

All catalog units are rated to ANSI pressure Class 150

- Provides pressure vessels (tanks) that are either carbon, 304 or 316 stainless steel

Standard offering includes units rated for up to and including ANSI pressure class 600 (application review required)

- Provides pressure vessels (tanks) available in carbon steel, 304 or 316 stainless steel materials
- Includes schedule 40, standard and 80 pipe used in the pressure vessel construction

Catalog units provided with NPT or ANSI Class 150 nozzle connection

- Makes installation easy. Inlet and outlet nozzle connections are threaded MNPT on 8 in. (203 mm) and smaller tanks. Class 150 flanged connections on 10 in. (254 mm) and larger tanks

Mounting lugs are welded onto the tank wall of all 2½ in. (64 mm) NPT and larger units

- Provides mounting support

General purpose, moisture resistant enclosures available

- Offers easy access to terminal wiring

Flange mounting holes

- Straddles centerline to comply with industry standards

UL® and CSA component recognition under file numbers E52951 and 31388 respectively

- Meets industry safety standards

Typical Applications

Water:

- Deionized
- Demineralized
- Clean
- Potable
- Process
- Industrial water rinse tanks
- Hydraulic oil, crude, asphalt
- Lubricating oils at API specified watt densities
- Heat transfer oil
- Paraffin
- Caustic cleaners
- Nitrogen, hydrogen and other air/gas systems
- Superheating steam

Options

Terminal Enclosures

General purpose terminal enclosures, without thermostats, are supplied on all Watlow circulation heaters. Moisture and explosion resistant ratings are available to meet specific application needs.

Stand-off Terminal Enclosures

Stand-off terminal enclosures help protect terminal enclosures against excessive temperatures.

ASME Pressure Vessel Code Welding

Flange or screw plug assemblies can be provided with an ASME Section VIII or Section I, Div. I pressure vessel stamp upon request.

Branch Circuits

Branch circuits are designed for 48 amperes per circuit maximum. Contact a Watlow representative for circuit requirements other than those listed in the stock charts.

Certified Enclosures

CSA, ATEX or IECEx certified enclosures protect wiring in hazardous gas environments. These terminal enclosures, covered under CSA file number 61707, ATEX certificate # SIRA 10ATEX 1155X or IECEx certificate # IECEx CSA 09.0010 are available on WATROD flange heaters.

For products that will be installed in hazardous locations, please provide the following information:

- Operating conditions
- Minimum and maximum ambient temperatures for the installation location
- Mounting orientation

Watlow must understand this information so that an appropriate design can be provided.

Thermostats

To provide process temperature control, Watlow offers optional single- and double-pole thermostats. Thermostats are typically mounted in the terminal enclosure. Optional side mounting on vessel also available.

Baffles

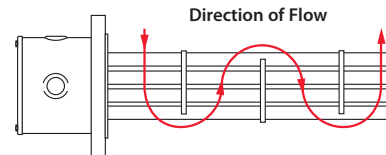

Baffles mounted on the heating element bundle enhance and/or modify liquid or gas flow for better heat transfer. For critical sheath temperature and low flow conditions, baffles may be required.

Contact a Watlow representative for details.

Thermocouples

To sense process or element sheath temperature, ASTM Type J or K thermocouples are available.

Options (Continued)

Process Thermocouple in Nozzle (Must specify which nozzle)

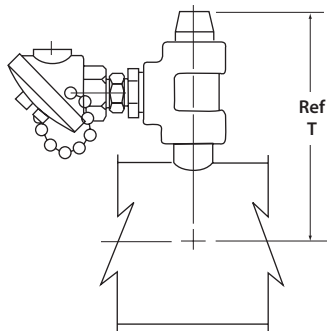

Ref. Tank Size	Ref. Nozzle Size	Dimension "A"
1 ¹ / ₄	³ / ₄ NPT	8 ³ / ₁₆
2 ¹ / ₂	1 NPT	8 ³ / ₁₆
3	1 NPT	8 ³ / ₁₆
4	1 ¹ / ₂ NPT	10 ³ / ₈
5	2 NPT	11 ¹ / ₁₆
6	2 ¹ / ₂ NPT	13 ³ / ₈
8	2 ¹ / ₂ NPT	14 ³ / ₈

For 10 in. (254 mm) and larger tanks contact your Watlow representative for dimension.

Sheath Materials

The following sheath materials are available on WATROD and FIREBAR heating elements:

Standard Sheath Materials

WATROD	Alloy 800/840 316 SS Steel
FIREBAR	Alloy 800, 304 SS

Made-to-Order Sheath Materials

WATROD	304 SS Alloy 600 Titanium Hastelloy® C276
--------	--

Wattages and Voltages

Watlow routinely supplies circulation heaters with 120 to 690VAC as well as wattages from 500 watts to one megawatt. If required, Watlow will configure circulation heaters with voltages and wattages outside these parameters.

For more information on special voltage and wattage configurations, contact a Watlow representative.

Protective Steel Jacket (Shroud)

To protect circulation heaters from weather or wash-down conditions, partially welded (standard) outer protective steel jackets are available. Standard steel, or made-to-order 304 or 316 stainless steel or aluminum can be supplied. Jacket diameter is dependent upon thermal insulation thickness.

To order, specify **protective steel jacket, material type and weatherproof**, if desired.

Passivated Finish

For critical applications, passivation will remove free iron from all wetted surfaces.

Contact a Watlow representative for details.

Gaskets

Rubber, asbestos-free and spiral wound gaskets are available for all heater flange, and inlet and outlet flange sizes.

Watlow recommends ordering spares in case replacement becomes necessary.

To order, specify **gasket type, flange size/rating and process operating temperature**.

Inlet and Outlet Nozzle Connections

All inlet and outlet materials are compatible with the pressure vessel material and pressure class rating.

Vessel sizes from 1¹/₄ to 8 inches are typically configured with Male National Pipe Thread (MNPT) nozzles. Optional NPT and flange sizes can be supplied to mate with existing piping.

10 inch and larger vessels are supplied with Class 150 inlet and outlet flanges. Optional Class 300 or Class 600 can be provided to mate with existing piping.

To order, specify **type, size and pressure class** rating for both inlet and outlet nozzle/flange connections.

Support Saddles

To mate with an existing installation, customized support saddle(s) and/or mounting lugs are available.

To order, specify **mounting lugs or support saddles** and supply a dimensional drawing.

High-Temperature Thermal Insulation

To further minimize heat loss, the pressure vessel's standard one inch thermal insulation wrap may be replaced with thicker and/or higher temperature insulation.

For more information, contact your Watlow representative.

To order, specify **insulation thickness, standard or high temperature insulation and temperature rating**.

Vessels may be supplied with a primer coating without insulation.

To order, specify **no insulation**.

Pressure Vessels

All catalog pressure vessel (tank) materials consist of standard schedule and 150# class forged fittings and are made from one of the following materials:

- Carbon steel
- 316 stainless steel

All catalog pressure vessels (tanks) are steel unless otherwise noted.

316 stainless steel pressure vessels (tanks) are passivated on all wetted surfaces. Available from assembly stock on 2¹/₂ inch NPT and 4 or 6 inch ANSI flange circulation heaters.

Made-to-order units can be made in a variety of materials, flange sizes and pressure classes. Ratings to ANSI class 2500 pressure class are available for high-pressure applications.

Ordering Information

Part Number

① Stock Plug or ANSI Flange Part Number	② Optional Terminal Enclosures	③ Optional Process Sensors	④ Sheath Limit Sensors



① Stock Plug or ANSI Flange Part Number
Insert Part Number
Note: Catalog part numbers include optional enclosures and process sensors. To order optional enclosures or sensors, substitute the appropriate suffix.

② Optional Terminal Enclosure
S = General purpose enclosure
W = Moisture resistant enclosure
E = Explosion resistant enclosure
C = Moisture/explosion resistant enclosure
Note: Catalog listings include either a general purpose enclosure or moisture/explosion resistant enclosure. Substitute enclosure options are noted.

③ Optional Process Sensor
2 = 30 to 250°F (-1 to 121°C), SPST
3 = 175 to 550°F (79 to 288°C), SPST
4 = 40 to 110°F (-1 to 43°C), DPST
5A = 60 to 250°F (16 to 121°C), DPST (FIREBAR)
7A = 100 to 500°F (38 to 288°C), DPST (FIREBAR)
J = Type J process thermocouple in thermowell
K = Type K process thermocouple in thermowell

④ Sheath Limit Sensor
HJ = Type J high-limit thermocouple, horizontal mount
TJ = Type J high-limit thermocouple, vertical/housing at top
BJ = Type J high-limit thermocouple, vertical/housing at bottom
HK = Type K high-limit thermocouple, horizontal mount
TK = Type K high-limit thermocouple, vertical/housing at top
BK = Type K high-limit thermocouple, vertical/housing at bottom
Note: Heater orientation is critical to accurate sensing of limit conditioners. Use the appropriate code to indicate heater mounting orientations.



Watlow® and FIREBAR® are registered trademarks of Watlow Electric Manufacturing Company.
 WATROD™ is trademark of Watlow Electric Manufacturing Company.
 UL® is a registered trademark of Underwriter's Laboratories, Inc.
 Hastelloy® is a registered trademark of Haynes International.

Powered by Possibility



To be automatically connected to the nearest North American Technical Sales Office:
1-800-WATLOW2 • www.watlow.com
inquiry@watlow.com

International Technical Sales Offices:

Austria	+43 6244 20129 0	India	+91 40 6661 2700
China	+86 21 3532 8532	Italy	+39 02 458 8841
France	+33 1 41 32 79 70	Japan	+81 3 3518 6630
Germany	+49 7253 9400 0	Korea	+82 2 2169 2600

Mexico	+52 442 256 2200
Singapore	+65 6773 9488
Spain	+34 91 675 1292
Taiwan	+886 7 288 5168
UK	+44 115 964 0777

Circulation Heaters



WATROD and FIREBAR Circulation Heaters



Application: Process Water^⑤

- WATROD elements
- Without thermostat
- General purpose enclosure

Description	Volts	kW	Ph	# Circ.	Part Number	WATCONNECT Part Number		Ship Wt. lbs (kg)	"A" Dim. in. (mm)		"N" Dim. in. (mm)		"C" Dim. in. (mm)	
						Type J T/C	Type K T/C							
10 inch - 150 lb ANSI Flange (WATROD)														
48 W/in ² ^⑥ Steel Tank 27-Alloy 800 Elements (7.5 W/cm ²)	480	262.0	3	9	CFSN773E5S	C/F	C/F	600 (273)	106 ⁵ / ₈ (2708.3)	90 ⁷ / ₈ (2308.2)	97 ⁵ / ₁₆ (2471.7)			
12 inch, 150 lb ANSI Flange (WATROD)														
48 W/in ² Steel Tank 36-Alloy 800 Elements (7.5 W/cm ²)	480	350.0	3	12	CFTN773C5S	C/F	C/F	650 (295)	106 ¹ / ₂ (2705)	90 ³ / ₈ (2295.5)	97 ¹ / ₈ (2467.0)			
14 inch - 150 lb ANSI Flange (WATROD)														
48 W/in ² Steel Tank 45-Alloy 800 Elements (7.5 W/cm ²)	480	315.0	3	15	CFWN754J5S	C/F	C/F	600 (273)	83 ¹ / ₄ (2115)	67 (1700)	73 ¹¹ / ₁₆ (1871.7)			
	480	375.0	3	15	CFWN763J5S	C/F	C/F	650 (295)	90 ³ / ₄ (2305)	74 ¹ / ₂ (1891)	81 ³ / ₁₆ (2062.2)			

⑤ When steel vessel materials are used in this application, some rust may be present in the process media

⑥ Can be wired for 1-phase operation

C/F - Contact factory, go to www.watlow.com/en/contact-us

10 inch - 150 lb ANSI Flange

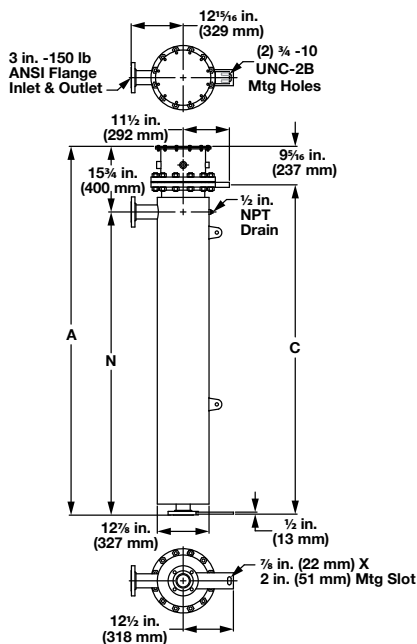

12 inch - 150 lb ANSI Flange

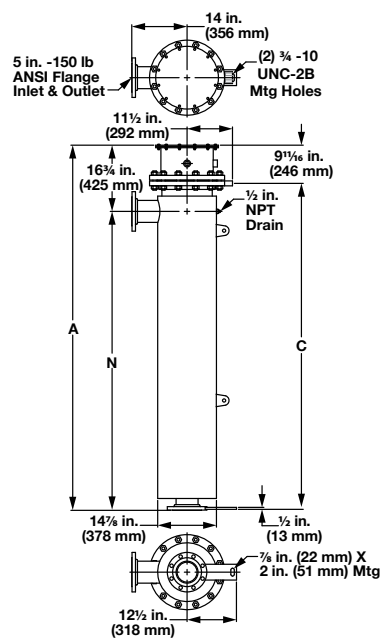

14 inch - 150 lb ANSI Flange

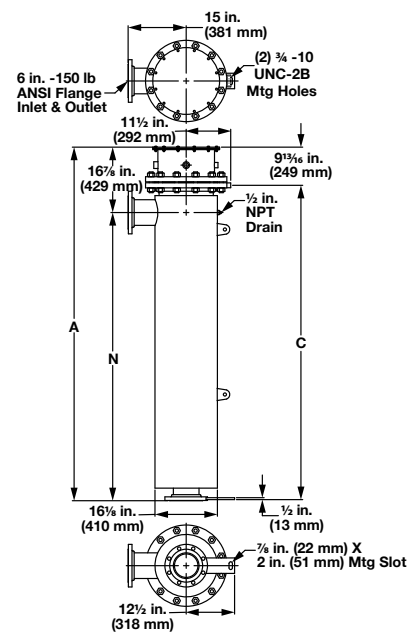

Circulation Heaters



WATROD and FIREBAR Circulation Heaters



Application: Forced Air and Caustic Solutions

- WATROD elements
- Without thermostat
- General purpose enclosure

Description	Volts	kW	Ph	# Circ.	Part Number	WATCONNECT Part Number		Ship Wt. lbs (kg)	"A" Dim. in. (mm)	"N" Dim. in. (mm)	"C" Dim. in. (mm)
						Type J T/C	Type K T/C				
10 inch - 150 lb ANSI Flange (WATROD)											
23 W/in ² Steel Tank 27-Alloy 800 Elements (3.6 W/cm ²)	240	60.0	3	3	CFSNA43N3S	C4-144	C4-145	515 (234)	76 ⁵ / ₈ (1946.3)	60 ⁷ / ₈ (1546.2)	67 ⁵ / ₁₆ (1709.7)
	480	60.0	3	3	CFSNA43N5S	C4-150	C4-151	515 (234)	76 ⁵ / ₈ (1946.3)	60 ⁷ / ₈ (1546.2)	67 ⁵ / ₁₆ (1709.7)
	240	75.0	3	9	CFSNA51N3S	C/F	C/F	530 (241)	84 ¹ / ₈ (2136.8)	68 ³ / ₈ (1736.2)	74 ¹³ / ₁₆ (1900.2)
	480	75.0	3	3	CFSNA51N5S	C4-152	C4-153	530 (241)	84 ¹ / ₈ (2136.8)	68 ³ / ₈ (1736.2)	74 ¹³ / ₁₆ (1900.2)
12 inch - 150 lb ANSI Flange (WATROD)											
23 W/in ² Steel Tank 36-Alloy 800 Elements (3.6 W/cm ²)	480	80.0	3	3	CFTNA43L5S	C4-152	C4-153	565 (257)	76 ⁷ / ₈ (1952.6)	60 ³ / ₄ (1541)	67 ¹ / ₂ (1714.0)
	480	100.0	3	3	CFTNA51L5S	C4-152	C4-153	585 (266)	84 ³ / ₈ (2143.1)	68 ¹ / ₄ (1732)	75 (1905.0)
14 inch - 150 lb ANSI Flange (WATROD)											
23 W/in ² Steel Tank 45-Alloy 800 Elements (3.6 W/cm ²)	480	100.0	3	3	CFWNA43J5S	C4-152	C4-153	570 (259)	75 ³ / ₄ (1924)	59 ¹ / ₂ (1510)	66 ³ / ₁₆ (1681.2)
	480	125.0	3	5	CFWNA51J5S	C/F	C/F	590 (268)	83 ¹ / ₄ (2115)	67 (1700)	73 ¹¹ / ₁₆ (1871.7)

C/F - Contact factory, go to www.watlow.com/en/contact-us

10 inch - 150 lb ANSI Flange

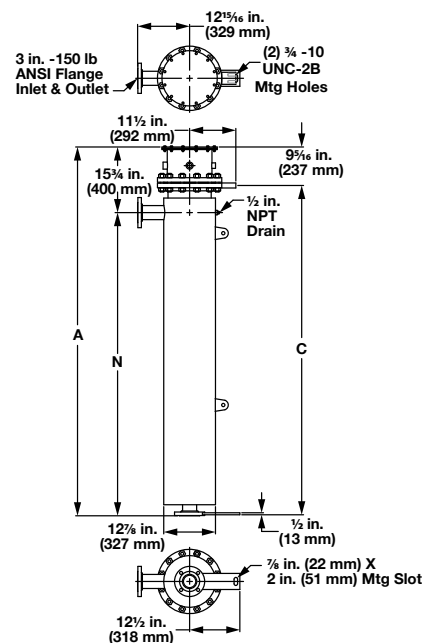

12 inch - 150 lb ANSI Flange

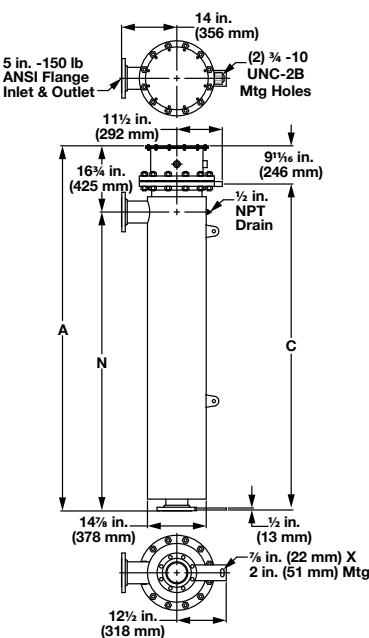

14 inch - 150 lb ANSI Flange

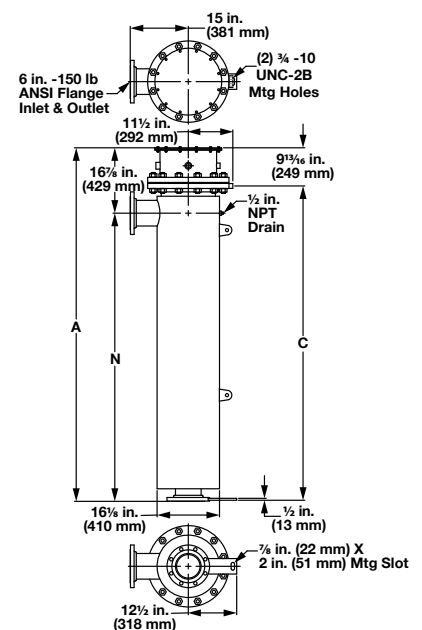

Circulation Heaters



WATROD and FIREBAR Circulation Heaters



Application: Lightweight Oils and Heat Transfer Oils

- WATROD elements
- Without thermostat
- General purpose enclosure

Description	Volts	kW	Ph	# Circ.	Part Number	WATCONNECT Part Number		Ship Wt. lbs (kg)	"A" Dim. in. (mm)	"N" Dim. in. (mm)	"C" Dim. in. (mm)
						Type J T/C	Type K T/C				
10 inch - 150 lb ANSI Flange (WATROD)											
23 W/in ² Steel Tank 27-Steel Elements (3.6 W/cm ²)	480	90.0	3	3	CFSS762E5S	C4-152	C4-153	540 (245)	91 ¹ / ₄ (2316.0)	75 ¹ / ₂ (1916.0)	81 ¹⁵ / ₁₆ (2081.2)
	480	105.0	3	3	CFSS770N5S	C4-152	C4-153	600 (645)	99 ¹ / ₈ (2517.8)	83 ³ / ₈ (2117.7)	89 ¹³ / ₁₆ (2281.2)
	480	120.0	3	3	CFSS778N5S	C4-152	C4-153	645 (293)	106 ⁵ / ₈ (2708.3)	90 ⁷ / ₈ (2308.2)	97 ⁵ / ₁₆ (2471.7)
12 inch - 150 lb ANSI Flange (WATROD)											
23 W/in ² Steel Tank 36-Steel Elements (3.6 W/cm ²)	480	140.0	3	4	CFTS770L5S	C4-156	C4-157	650 (295)	99 (2515)	82 ⁷ / ₈ (2105.0)	89 ⁵ / ₈ (2276.5)
	480	160.0	3	4	CFTS778L5S	C4-156	C4-157	700 (318)	106 ¹ / ₂ (2705)	90 ³ / ₈ (2295.5)	97 ¹ / ₈ (2467.0)
14 inch - 150 lb ANSI Flange (WATROD)											
23 W/in ² Steel Tank 45-Steel Elements (3.6 W/cm ²)	480	150.0	3	5	CFWS762A5S	C/F	C/F	650 (295)	90 ³ / ₄ (2305)	74 ¹ / ₂ (1891)	81 ³ / ₁₆ (2062.2)
	480	175.0	3	5	CFWS770J5S	C/F	C/F	700 (318)	98 ¹ / ₄ (2496)	82 (2081)	88 ¹¹ / ₁₆ (2252.7)
	480	200.0	3	5	CFWS778J5S	C/F	C/F	780 (354)	105 ³ / ₄ (2686)	89 ¹ / ₂ (2272)	96 ³ / ₁₆ (2443.2)

C/F - Contact factory, go to www.watlow.com/en/contact-us

10 inch - 150 lb ANSI Flange

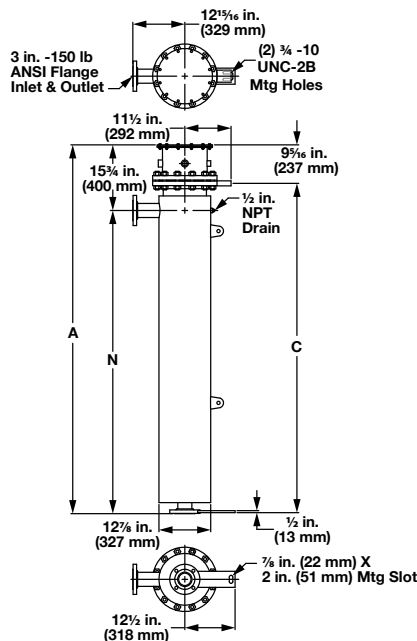

12 inch - 150 lb ANSI Flange

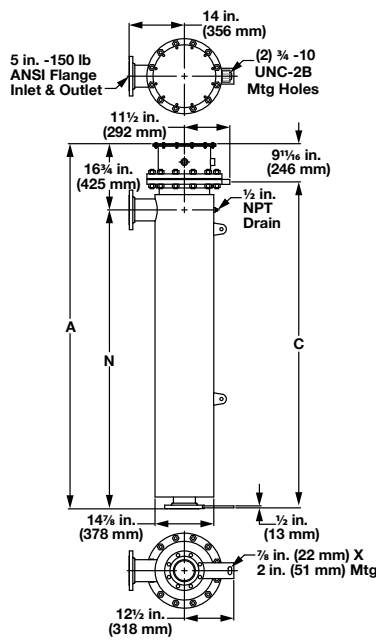

14 inch - 150 lb ANSI Flange

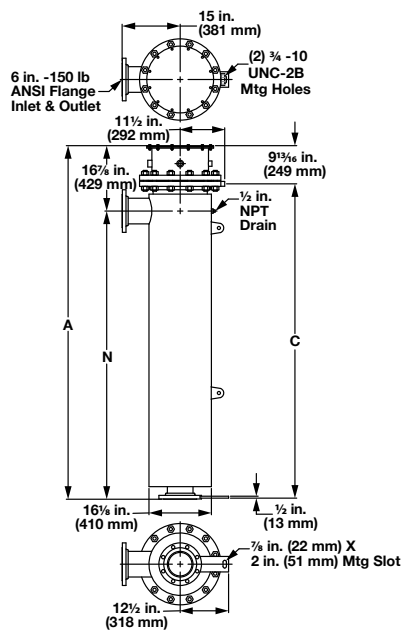

Circulation Heaters



WATROD and FIREBAR Circulation Heaters



Application: Bunker C, Asphalt and #6 Fuel Oil

- WATROD elements
- Without thermostat
- General purpose enclosure

Description	Volts	kW	Ph	# Circ.	Part Number	WATCONNECT Part Number		Ship Wt. lbs (kg)	"A" Dim. in. (mm)	"N" Dim. in. (mm)	"C" Dim. in. (mm)
						Type J T/C	Type K T/C				
10 inch - 150 lb ANSI Flange (WATROD)											
8 W/in² ^③ Steel Tank 27-Steel Elements (1.3 W/cm²)	240	30.0	3	3	CFSS762E12S	C4-143	C4-142	540 (245)	91 ¹ / ₄ (2316.0)	75 ¹ / ₂ (1916.0)	82 ¹ / ₄ (2088.0)
	480	30.0	3	1	CFSS762E13S	C2-225	C2-226	540 (245)	91 ¹ / ₄ (2316.0)	75 ¹ / ₂ (1916.0)	82 ¹ / ₄ (2088.0)
	240	35.0	3	3	CFSS770N12S	C4-144	C4-145	600 (273)	99 ¹ / ₈ (2517.8)	83 ³ / ₈ (2117.7)	89 ¹³ / ₁₆ (2281.2)
	480	35.0	3	1	CFSS770N13S	C2-225	C2-226	600 (273)	99 ¹ / ₈ (2517.8)	83 ³ / ₈ (2117.7)	89 ¹³ / ₁₆ (2281.2)
	240	40.0	3	3	CFSS778N12S	C4-144	C4-145	645 (293)	106 ⁵ / ₈ (2708.3)	90 ⁷ / ₈ (2308.2)	97 ⁵ / ₁₆ (2471.7)
	480	40.0	3	1	CFSS778N13S	C2-225	C2-226	645 (293)	106 ⁵ / ₈ (2708.3)	90 ⁷ / ₈ (2308.2)	97 ⁵ / ₁₆ (2471.7)

③ Wired for 3-phase operation only

10 inch - 150 lb ANSI Flange

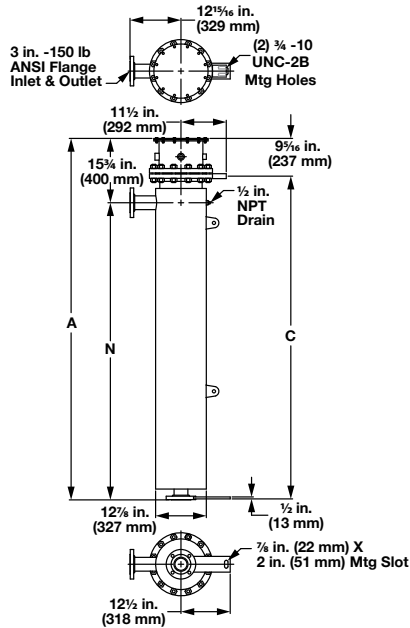

Circulation Heaters



WATROD and FIREBAR Circulation Heaters



Application: Bunker C, Asphalt and #6 Fuel Oil

- WATROD elements
- Without thermostat
- General purpose enclosure

Description	Volts	kW	Ph	# Circ.	Part Number	WATCONNECT Part Number		Ship Wt. lbs (kg)	"A" Dim. in. (mm)		"N" Dim. in. (mm)		"C" Dim. in. (mm)	
						Type J T/C	Type K T/C							
12 inch - 150 lb ANSI Flange (WATROD)														
8 W/in² ③ Steel Tank 36-Steel Elements (1.3 W/cm²)	240	47.0	3	3	CFTS770L12S	C4-144	C4-145	700 (318)	99	(2515)	82 ⁷ / ₈	(2105.0)	89 ⁵ / ₈	(2277)
	480	47.0	3	2	CFTS770L13S	C2-229	C2-230	700 (318)	99	(2515)	82 ⁷ / ₈	(2105.0)	89 ⁵ / ₈	(2277)
	240	54.0	3	3	CFTS778L12S	C4-144	C4-145	750 (341)	106 ¹ / ₂	(2705)	90 ³ / ₈	(2295.5)	97 ¹ / ₈	(2467)
	480	54.0	3	2	CFTS778L13S	C2-229	C2-230	750 (341)	106 ¹ / ₂	(2705)	90 ³ / ₈	(2295.5)	97 ¹ / ₈	(2467)
14 inch - 150 lb ANSI Flange (WATROD)														
8 W/in² ③ Steel Tank 45-Steel Elements (1.3 W/cm²)	240	60.0	3	3	CFWS770J12S	C4-144	C4-145	700 (318)	98 ¹ / ₄	(2496)	82	(2081)	88 ¹¹ / ₁₆	(2253)
	480	60.0	3	3	CFWS770J13S	C4-150	C4-151	700 (318)	98 ¹ / ₄	(2496)	82	(2081)	88 ¹¹ / ₁₆	(2253)
	240	67.0	3	5	CFWS778J12S	C/F	C/F	780 (354)	105 ³ / ₄	(2686)	89 ¹ / ₂	(2272)	96 ³ / ₁₆	(2443)
	480	67.0	3	3	CFWS778J13S	C4-152	C4-153	780 (354)	105 ³ / ₄	(2686)	89 ¹ / ₂	(2272)	96 ³ / ₁₆	(2443)

C/F - Contact factory, go to www.watlow.com/en/contact-us

12 inch - 150 lb ANSI Flange

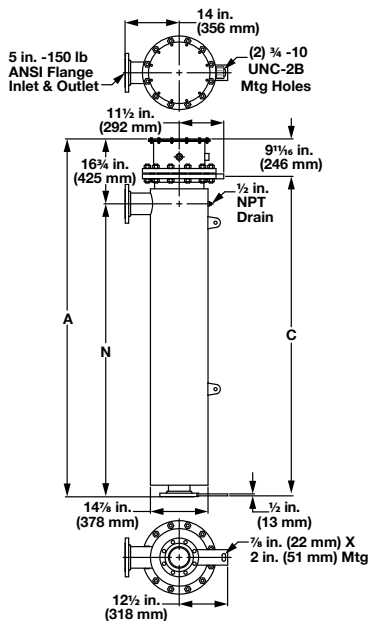

14 inch - 150 lb ANSI Flange

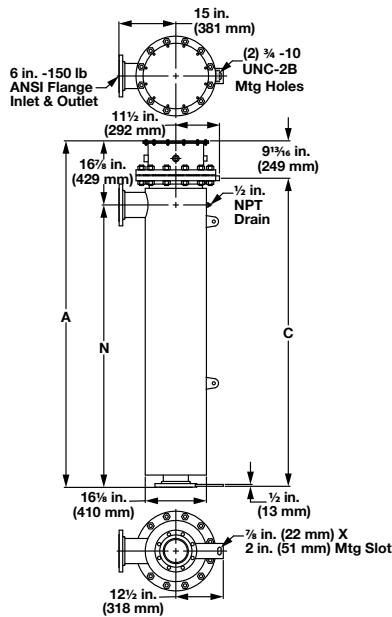

Circulation Heaters



WATROD and FIREBAR Circulation Heaters

Part Number

Stock Plug or ANSI Flange Part Number	Optional Terminal Enclosures	Optional Process Sensors	Sheath Limit Sensors

Stock Plug or ANSI Flange Part Number
<p>Note: Catalog part numbers include optional enclosures and process sensors. To order optional enclosures or sensors, substitute the appropriate suffix.</p>

Optional Terminal Enclosures	
S =	General purpose enclosure
W =	NEMA 4 enclosure
C =	Moisture/explosion resistant enclosure
<p>Note: Catalog listings include either a general purpose enclosure or NEMA 4 enclosure. Substitute enclosure options are noted.</p>	

Optional Bulb and Capillary Thermostats or Thermocouple Process Sensors	
2 =	30 to 250°F, (-1 to 121°C) SPST
3 =	175 to 550°F, (79 to 288°C) SPST
4 =	40 to 110°F, (-1 to 43°C) DPST
5A=	60 to 250°F, (16 to 121°C) DPST (FIREBAR)
7A=	100 to 550°F, (38 to 288°C) DPST (FIREBAR)
J =	Type J process thermocouple in thermowell
K =	Type K process thermocouple in thermowell
<p>Note: Thermostat part numbers are shown in the <i>Thermostat Chart</i> on page 517.</p>	

Sheath Limit Sensors	
HJ=	Type J high-limit thermocouple, horizontal mount
TJ=	Type J high-limit thermocouple, vertical/housing at top
BJ=	Type J high-limit thermocouple, vertical/housing at bottom
HK=	Type K high-limit thermocouple, horizontal mount
TK=	Type K high-limit thermocouple, vertical/housing at top
BK=	Type K high-limit thermocouple, vertical/housing at bottom
<p>Note: Heater orientation is critical to accurate sensing of limit conditions. Use the appropriate code to indicate heater mounting orientation.</p>	

Example Part Number: CFONA18A10 S 5 HJ