

ANTI-STATIC BARS

NEOS 30 INTELLIGENT IONISING BARS

The NEOS range of static eliminators is a major advance in industrial static control technology. NEOS intelligence monitors and reacts to the static charge by emitting the quantity and polarity of ions to neutralise it. The combination of NEOS intelligence with intense ion generation creates static eliminators for the most demanding applications.

NEOS 30 is a long range static eliminator for distances between 200mm and 1500mm. For shorter ranges see also NEOS 20.

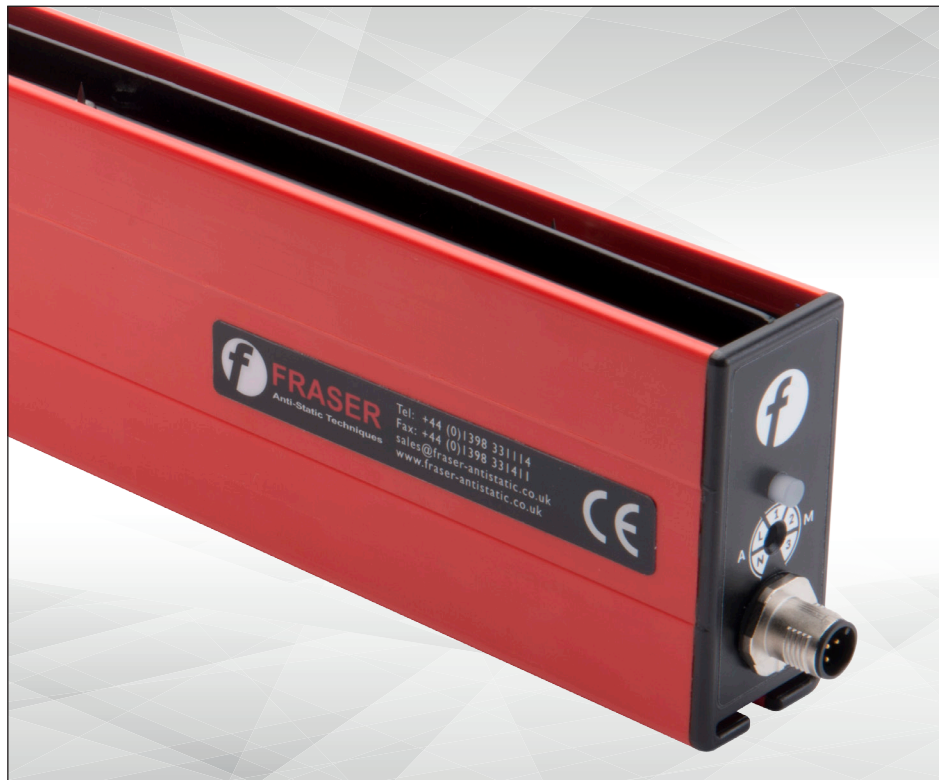

- > Shockless, resistively coupled replaceable emitters made in tungsten for long life.
- > NEOS Intelligence has two automatic and 3 manual settings to give the operator complete control. See page 2.
- > Remote and local monitoring of operation and "Clean Me" function.
- > LED status indication:
 - Green = OK
 - Red = Fault
 - Green and Red Flash = Clean Me, attention needed.
- > 100% coverage. Effective length = Overall length. No dead zone.
- > 24VDC supply, M12 5-pin connector.

Specification

Size:	NEOS 30 Min length 600mm then steps of 200mm to 5m.
Electrical Supply:	24V DC (21-27V), maximum current required 2.2A M12 5-pin connector.
Remote Monitor:	2 signals available: "HV OK" and "Attention" can be used to drive external loads or interface to systems (lamp, relay, PLC as required).
High Voltage Supply:	30kV supply integrated into Bar.
Construction:	Reinforced FR-ABS Industrial grade extrusion and end cap, fully encapsulated with epoxy resin.
Protection Classification:	IP67. Fully sealed.
Environment:	-10 to 55°C, 70% rH non-condensing.
Weight:	3.6 kg/m.
Certifications:	CE. (UL & CB - Pending)

NEOS Intelligence

The rotary switch at the cable end of the bar gives the operator full control over the NEOS bar. The default factory setting is AUTO NORMAL for intelligent operation within the working ranges of 200 - 750mm.

AUTO LONG may be chosen if the operating distance is always toward the long end of the range. The customer may also select to turn off the intelligent modes and run the bar as a standard static eliminator. There are 3 manual settings for **Short, Medium and Long Range** Operation.

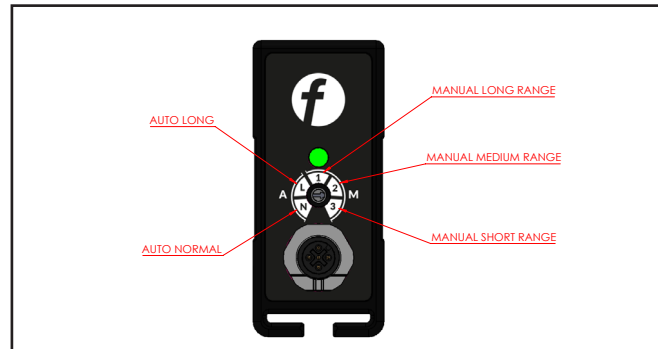

Dimensions - NEOS 30

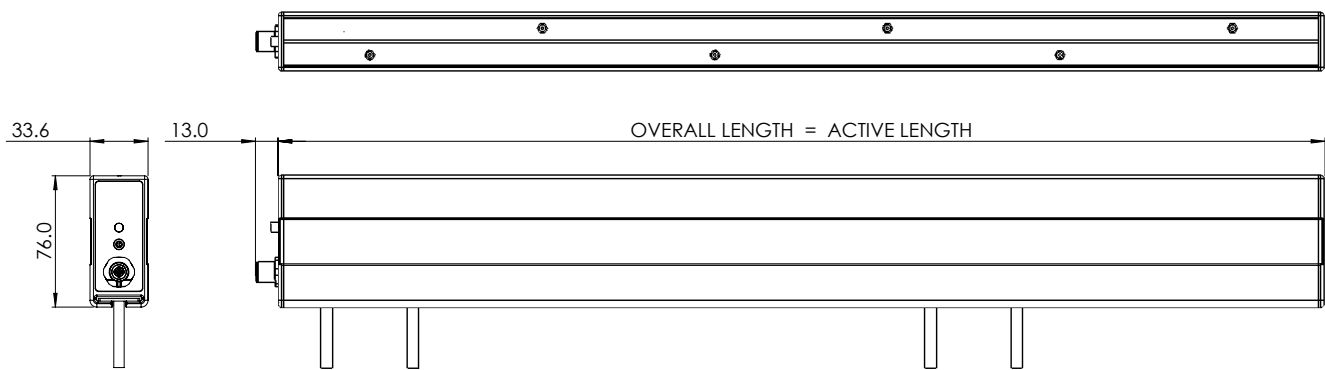

* note - overall length = nominal length + 6mm (including end cap)

Mounting

Each slide has 2 x M6 40mm studs. Two fixing slides for bars up to 1m, plus 1 extra for every additional 500mm.

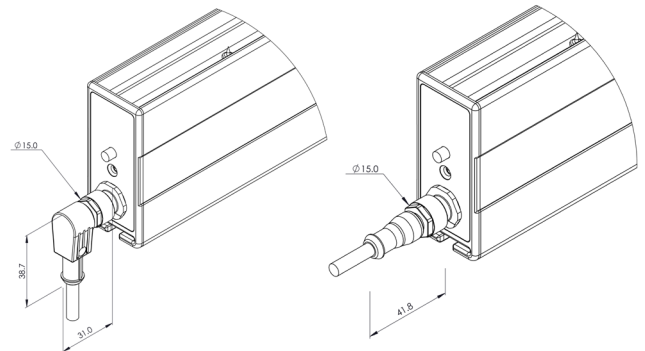

Accessories/Spares

Description	Part No.	Description	Part No.
3m cable with 180° connector	81193	3m cable with 90° connector	81199
5m cable with 180° connector	81194	5m cable with 90° connector	81200
7.5m cable with 180° connector	81195	7.5m cable with 90° connector	81201
10m cable with 180° connector	81196	10m cable with 90° connector	81202
Additional mounting set	34208	NEOS AC/DC 24V Power Supply*	342011

24V Cables must be ordered separately. They have standard M12 5-pin female connectors.

* Do not use ANY other standard power supplies with this product. Third party power supplies WILL cause damage and void warranty.